

Weather Resistant Louvres

- Type WSL
- Untreated aluminium

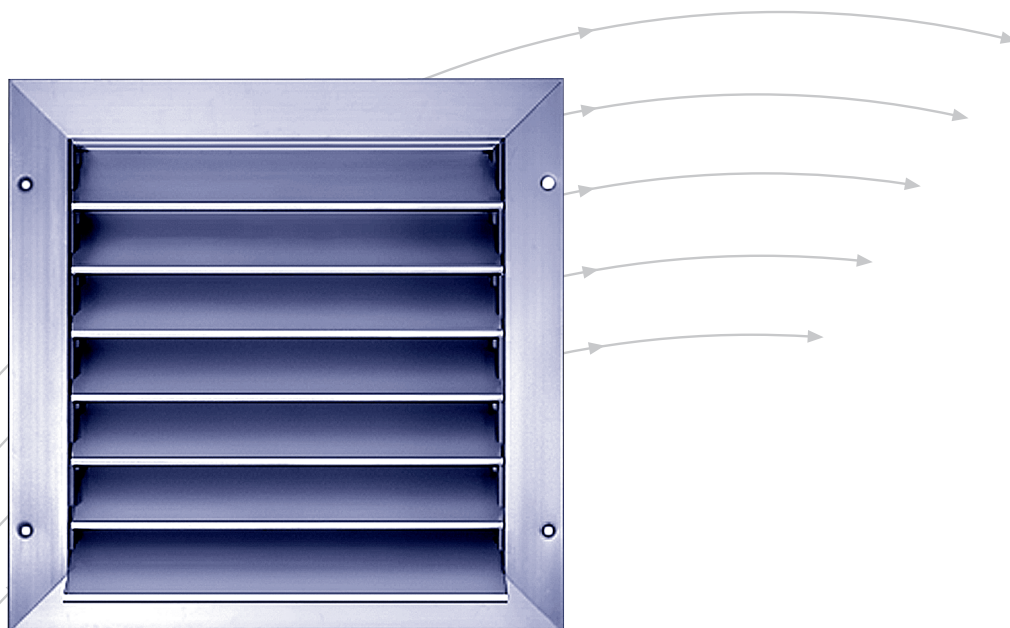

TROX[®] TECHNIK



The art of handling air

TROX HESCO Schweiz AG
Walderstrasse 125
Postfach 455
CH-8630 Rüti ZH

Tel. +41 55 250 71 11
Fax +41 55 250 73 10
www.troxhesco.ch
trox-hesco@troxgroup.com

Contents · Application · Realisation · Safety instructions

Contents

Application · Realisation · Safety instructions	2
Dimensions	3
Sizes	4
Installation · Accessories	5
Definitions · Quick selection	6
Technical Data	7-10
Order details	11

Application

TROX HESCO weather resistant louvres are installed in intake and outlet openings of buildings walls. They prevent rainwater and snow from entering.

Realisation

Angular frame and blades of untreated aluminium with galvanized wire mesh, mesh width 12 mm. The WSLs are available at extra cost in the following versions colorless or color anodized, with insect screen, galvanized.

Safety instructions



CAUTION!

Risk of injury from sharp edges and corners, ridges and thin-walled sheet metal parts!

- Proceed carefully with all work.
- Wear protective gloves, safety shoes and protective helmet.



WARNING!

Danger from incorrect use. Misuse of the product may lead to dangerous situations.

The product must not be used:

- in areas subject to explosion hazards;
- in the open air without sufficient protection against weather effects;
- in atmospheres that may have a damaging and/or corrosive effect on the product due to scheduled or unscheduled chemical reactions.



CAUTION!

Damage to the product due to improper handling. Check the device for damage and contamination prior to operation!

Improper handling may lead to considerable material damage of the product.

- Do not use any acid or abrasive cleaning agents.
- Adhesives from sticky tape may lead to colour damage.
- Excessive moisture may lead to colour damage and corrosion.
- Use only cleaning agents, greases and oils that are expressly specified.

Dimensions

B [mm]	H [mm]													
	200	250	300	350	400	500	600	700	800	1000	1250	1500	1750	2000
200														
250														
300														
350														
400														
500														
600														
700														
800														
1000														
1250														
1500														
1750														
2000														
2500											x	x	x	x
3000											x	x	x	x

- Common sizes
- Other sizes on request
- x in sections

Nominal width B × nominal height H
Free cross section: approx. 60%

$B + 87$
 $B - 10$
 48.5
 $H + 87$
 $H - 10$
 $\varnothing 7.4 \times 90^\circ$
 $H - 78$
 35
 $H > 1000$
 $B + 60$

1) Subdivision
 2) External dimensions
 3) Minimum recess
 4) $B > 1000$ mm with bridge, on the rear

4.7
 50
 30.5
 25
 19
 67
 63
 88

Nom. height H [mm]	
200	
250	
300	
350	
400	
500	
600	
700	
800	
1000	
1250	x
1500	x
1750	x
2000	x

Nom. width B [mm]	
200	
250	
300	
350	
400	
500	
600	
700	
800	
1000	
1250	
1500	
1750	x
2000	x
2500	x
3000	x

Remark: The nominal dimensions B and H are not measured!

x = for nominal sizes 2000 x 2000, 3000 x 1000 and 1000 x 3000 mm = individual louvres (supplied in one piece). Larger sizes in sections.

Sizes

Overview of WSL individual and continuous louvres

Remark: B × H are nominal sizes

Individual louvres

(supplied in one piece)

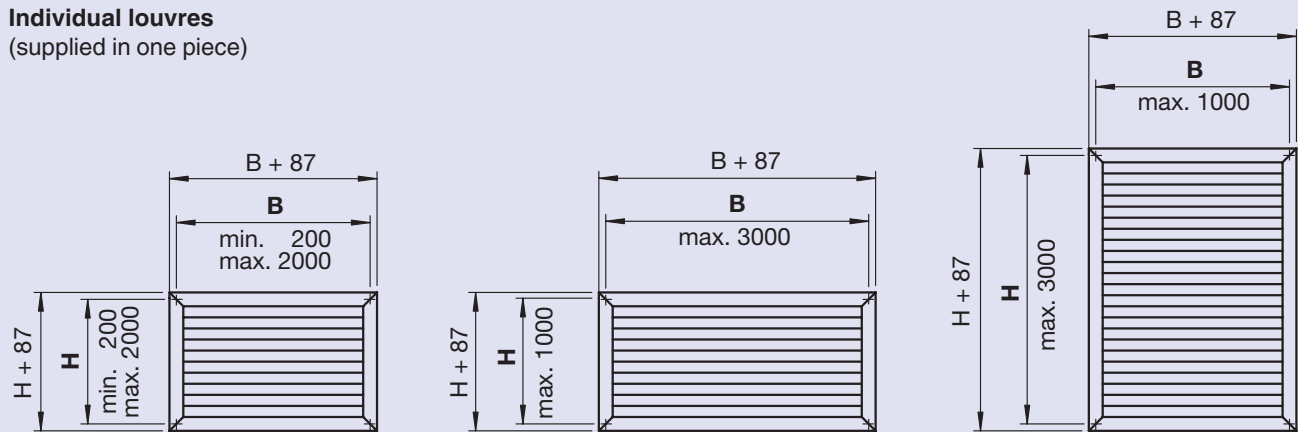

Continuous louvres «horizontal», type WSL - BH...

(supplied in sections)

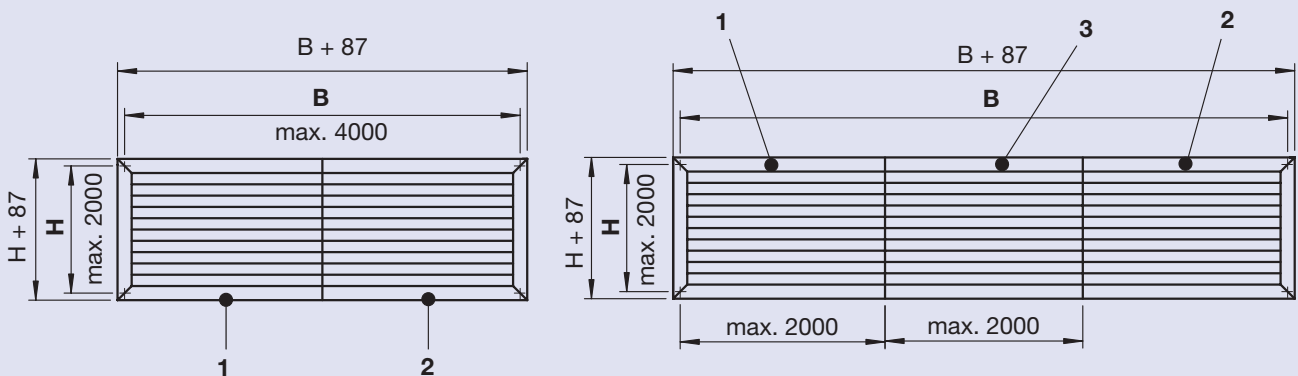

- 1 Left-hand terminal section horizontal
- 2 Right-hand terminal section horizontal
- 3 Intermediate section horizontal

Continuous louvres «vertical», type WSL - BV...

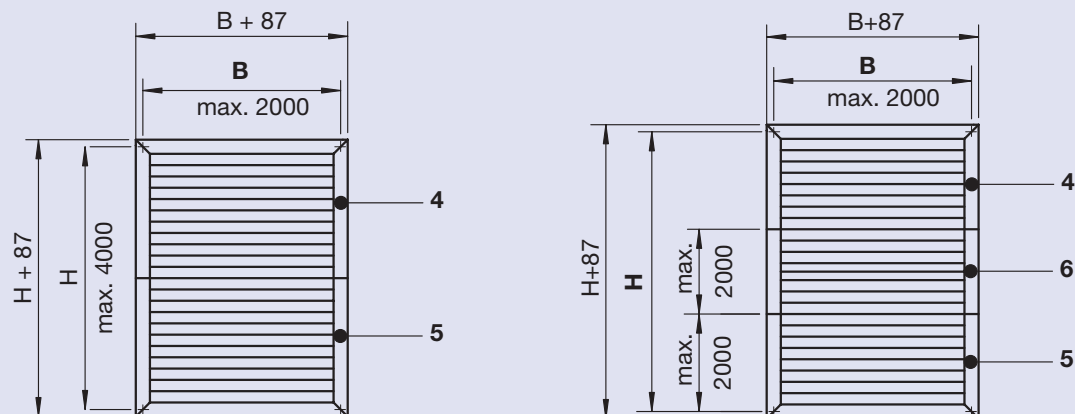

- 4 Upper terminal section vertical
- 5 Lower terminal section vertical
- 6 Intermediate section vertical

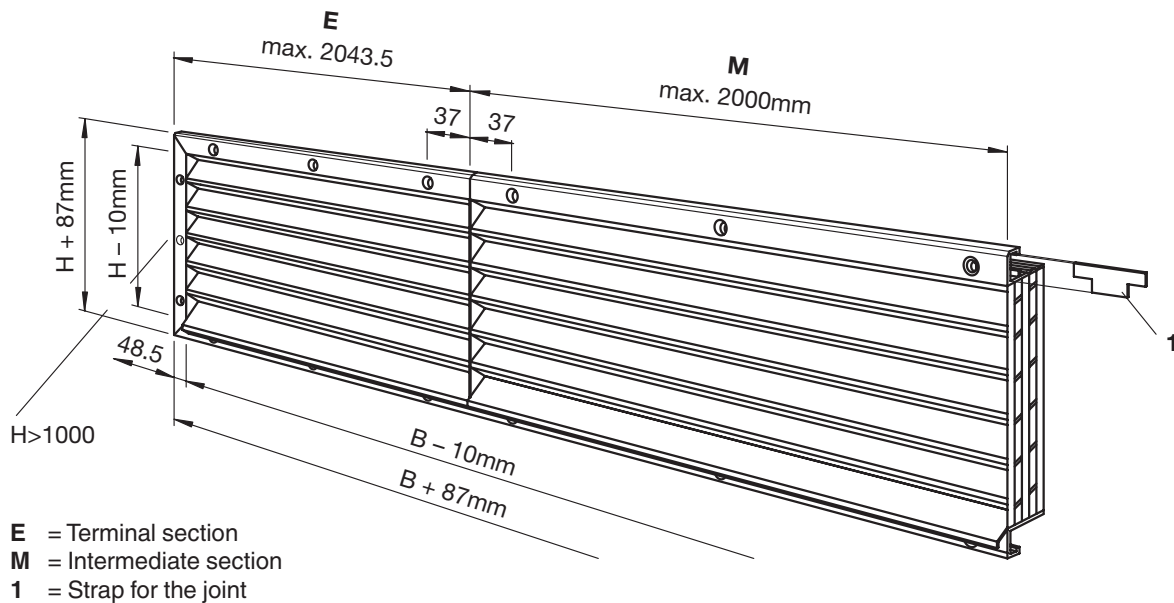

WSL Individual louvres

WSL individual louvres are available in the following versions:

- **Standard:** untreated aluminium with galvanized wire
- Aluminium painted according to RAL...
- Aluminium colorless anodised
- Aluminium colored anodised as per TROX HESCO color card
- Galvanized insect screen
- The lowest blade not protruding

Installation and accessories

Installation without wall frame in concrete or brick wall as well as in wood and metal structures.

The wide edge at the WSL to a great extent allows installing it **without** any wall frame.

min. recess dimensions = nominal width $B + 2$ mm
 = nominal height $H + 2$ mm

Included are: raised countersunk metal screws with slit $\varnothing 5.5 \times 25$ mm. (At site: dowels $\varnothing 7$ mm for concrete or brick wall).

Special installation situations

- a) Installation with wall frame
- b) Installation into wall with outside insulation
- c) Installation into gas concrete
- d) Installation without any screws visible

Please consult us for additional information!

WSL Continuous louvres

Application and Realisation as described previously.

Dimensions

WSL with a nominal width $B > 2000$ mm (or 3000 mm) are called continuous weather resistant louvres. Nominal widths B with graduation of 1 mm are available.

Common heights H , see individual louvres page 4 and table page 2. Sections of 50 to 50 mm are most common.

For special cases, nominal dimensions $B \times H$ within maximum sizes are available in any dimension.

Continuous WSL louvres are supplied in sections (terminal and intermediate sections).

Maximum length of a section = 2000 mm, see page 4 and above.

Definitions

L_w	dB	Sound power level
	dB(lin)	Linear sound power level
L_{wA}	dB(A)	A-weighted sound power level
A	m^2	Eff. nominal surface (B × H)
A_0	m^2	Nominal surface of reference
Δp_s	Pa	Pressure drop
Δp_t	Pa	Total pressure drop
\dot{z}	m^3/h	Air volume rate
\dot{z}_A	m^3/h	Extract air volume rate $\dot{z}_A = v_A \times A \times 3600$
\dot{z}_Z	m^3/h	Supply air volume rate $\dot{z}_Z = v_Z \times A \times 3600$
v_{gem}	m/s	Measured air velocity directly at the louvre
v_{gem}	m/min	Measured air velocity directly at the louvre

Quick selection

Air volume rate per m^2 (B × H)	\dot{z}	\leq	approx. 10 000 m^3/h
Air velocity in the duct	v_A	\leq	approx. 2.78 m/s
Sound power level per m^2	L_w		approx. 50 dB(A)
Pressure drop:			
– by discharge outlet	Δp_s Δp_t ζ		approx. 27 Pa, approx. 32 Pa approx. 7.2 (zeta value)
– by taking in fresh air	Δp_s Δp_t ζ		approx. 42 Pa, approx. 46 Pa approx. 10.3 (zeta value)

Determination of the air volume rate, extract air

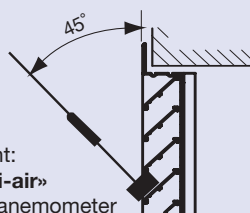
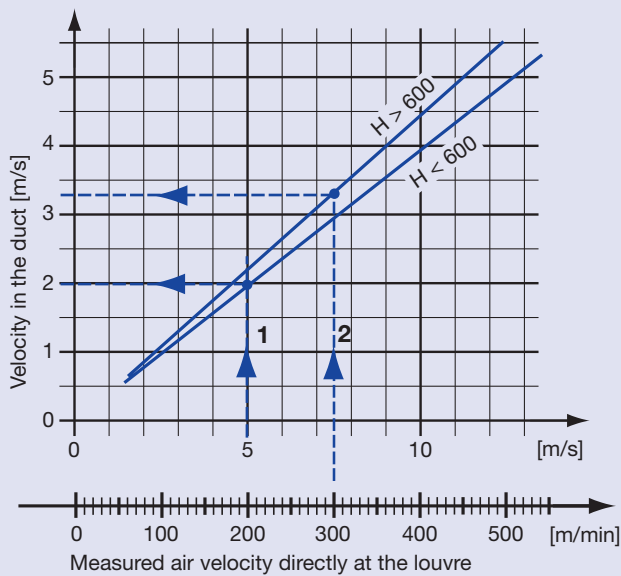

Measuring instrument:
 - Schiltknecht «mini-air»
 - Lambrecht minute anemometer

Example 1 (extract air)

Given

v_{gem} 5 m/s
 $B \times H$ $0.4 \times 0.4 \text{ m} = 0.16 \text{ m}^2$

Wanted

a) Air velocity v_A in the duct ($B \times H$) m/s
 b) Extract air volume rate \dot{V}_A m³/h

Solution

a) $v_A = 2.0 \text{ m/s}$
 b) $\dot{V}_A = v_A \times A \times 3600 = 2.0 \times 0.16 \times 3600 = 1152 \text{ m}^3/\text{h}$

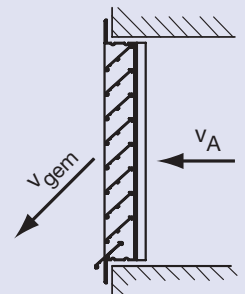

Example 2 (extract air)

Given

v_{gem} 300 m/min
 $B \times H$ $0.2 \times 1.0 \text{ m} = 0.20 \text{ m}^2$

Wanted

a) Air velocity v_A in the duct ($B \times H$) m/s
 b) Extract air volume rate \dot{V}_A m³/h

Solution

a) $v_A = 3.25 \text{ m/s}$
 b) $\dot{V}_A = v_A \times A \times 3600 = 3.25 \times 0.20 \times 3600 = 2340 \text{ m}^3/\text{h}$

Determination of the air volume rate, supply air

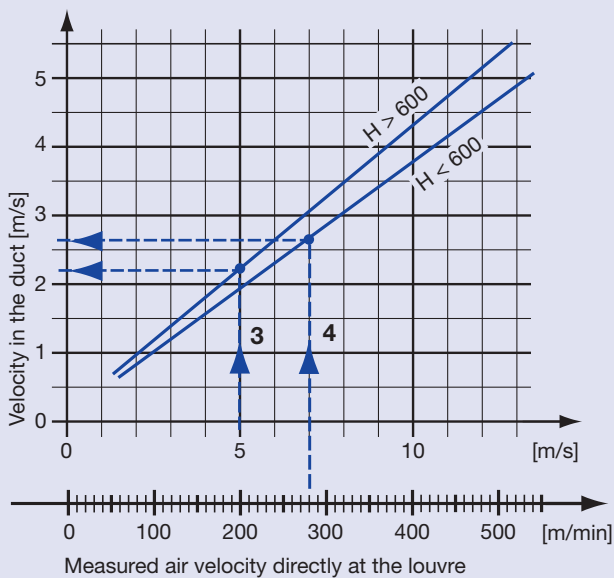

Example 3 (supply air)

Given

v_{gem} 5 m/s
 $B \times H$ $0.2 \times 1.0 \text{ m} = 0.20 \text{ m}^2$

Wanted

- a) Air velocity v_Z in the duct ($B \times H$) m/s
 b) Supply air volume rate \dot{V}_Z m³/h

Solution

- a) $v_A = 2.2 \text{ m/s}$
 b) $\dot{V}_Z = v_Z \times A \times 3600 = 2.2 \times 0.20 \times 3600 = 1584 \text{ m}^3/\text{h}$

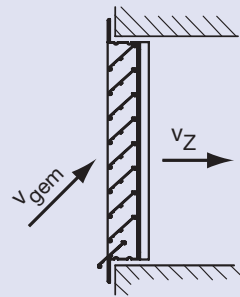

Example 4 (supply air)

Given

v_{gem} 280 m/min
 $B \times H$ $0.5 \times 0.5 \text{ m} = 0.25 \text{ m}^2$

Wanted

- a) Air velocity v_Z in the duct ($B \times H$) m/s
 b) Supply air volume rate \dot{V}_Z m³/h

Solution

- a) $v_Z = 2.6 \text{ m/s}$
 b) $\dot{V}_Z = v_Z \times A \times 3600 = 2.6 \times 0.25 \times 3600 = 2340 \text{ m}^3/\text{h}$

Sound power level, discharge opening

Sound power level L_W (A_0) and pressure drop Δp_t ; Δp_s

WSL 400x400mm

Nom. surface of reference $A_0 = 0.16 \text{ m}^2$

Sound power level of reference $W_0 = 10^{-12} \text{ W}$

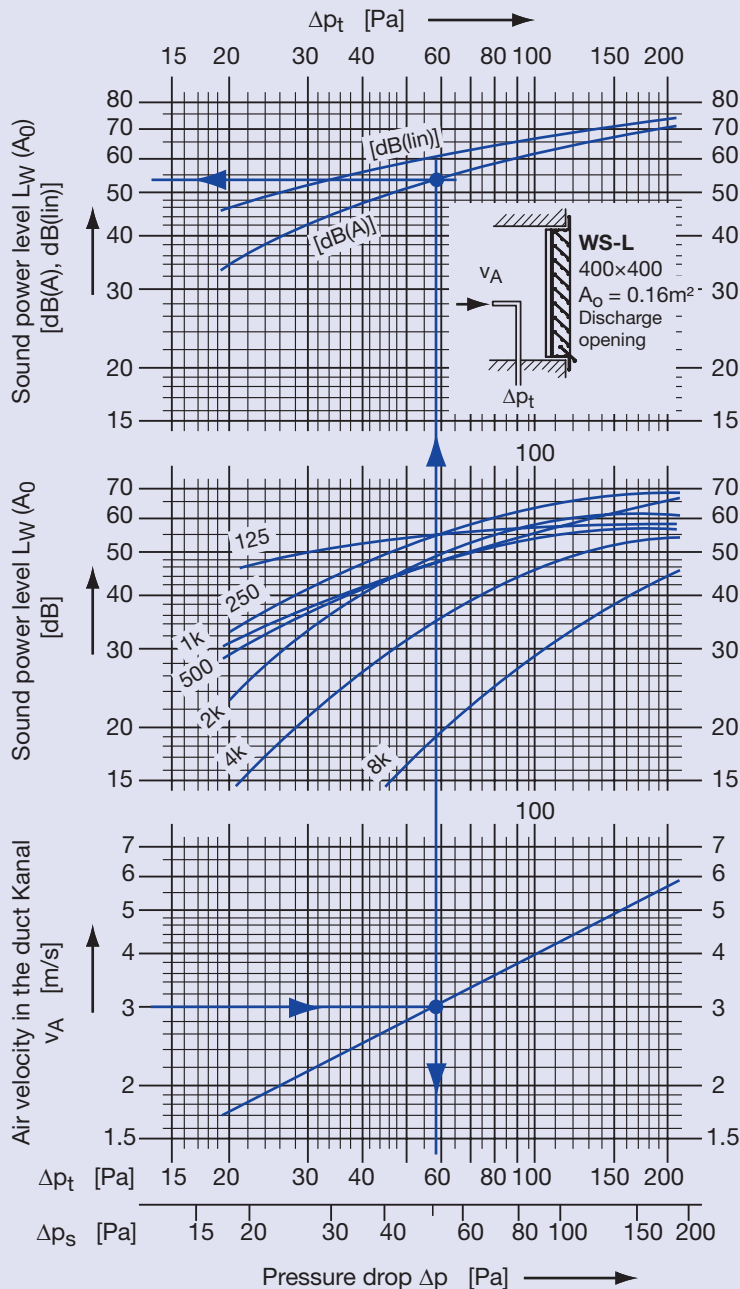

Example

WSL 200x400mm

$v_A = 3 \text{ m/s}$

Of diagram

L_W	by 0.16 m^2	=	53 dB(A)
Δp_s		=	50 Pa
A / A_0	= $0.08 / 0.16$	=	0.5
ΔL_W		=	+0 dB
L_W	= $53 + 0$	=	53 dB(A)
Δp_s Factor		=	1.3
Δp_s	= 50×1.3	=	65 Pa

Tolerances

Total level	$\pm 2 \text{ dB}$
Octave level	$\pm 4 \text{ dB}$

2. Correction «dimension of grille»

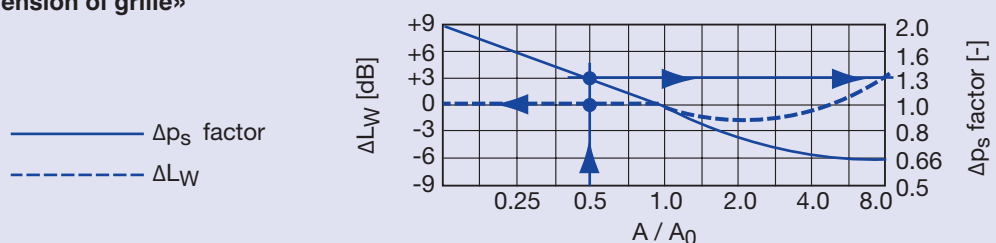

Technical Data

Sound power level, air inlet opening

Sound power level $L_W (A_0)$ and pressure drop Δp_t ; Δp_s

WSL 400x400mm

Nom. surface of reference $A_0 = 0.16 \text{ m}^2$

Sound power level of reference $W_0 = 10^{-12} \text{ W}$

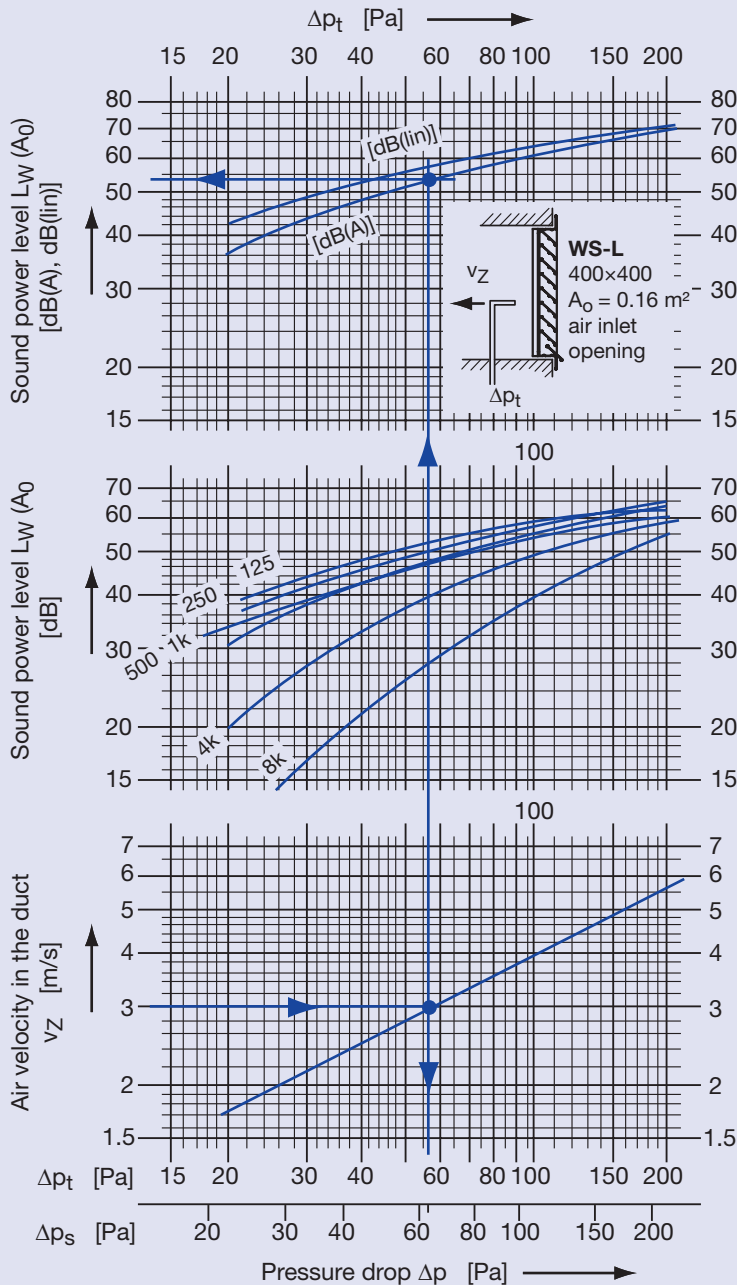

Example

WSL 200x400mm

$v_z = 3 \text{ m/s}$

Of diagram

L_w	by 0.16 m^2	= 52 dB(A)
Δp_s		= 62 Pa
A / A_0	= $0.08 / 0.16$	= 0.5
ΔL_w		= +1 dB
L_w	= $52 + 1$	= 53 dB(A)
Δp_s Factor		= 1.4
Δp_s	= 62×1.4	= 87 Pa

Tolerances

Total level $\pm 2 \text{ dB}$

Octave level $\pm 4 \text{ dB}$

2. Correction «dimension of grille»

A_0 Nom. surface of reference = 0.16 m^2

A Eff. nominal surface

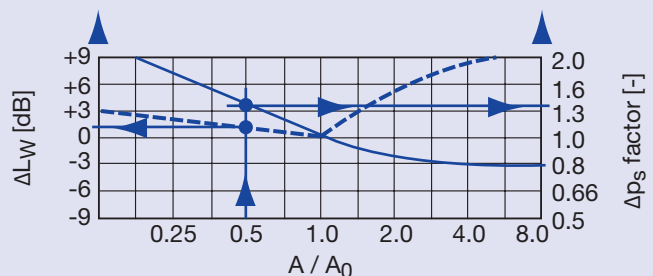
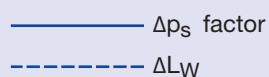

Order codes

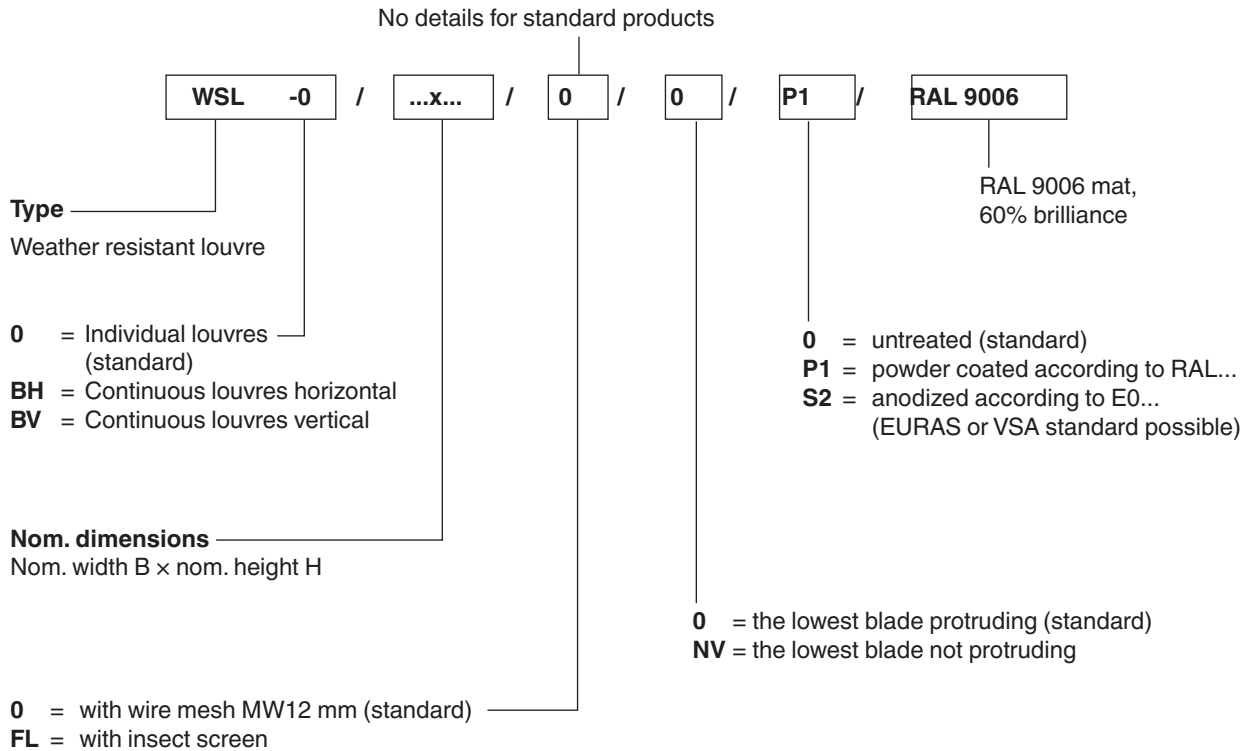

Order examples

- 2 off WSL / 600x400
- 1 off WSL / 800x600 / S2 (colorless anodized)
- 3 off WSL / 1000x500 / FL / NV
- 1 off WSL-BH / 6000x1500 / P1 / RAL 9006
(60% brilliance) existing of
2x terminal sections 2000x1500
1x intermediate section 2000x1500
- 1 off WSL-BV / 1800x8000 / NV
existing of
2x terminal sections 1800x2000
2x intermediate sections 1800x2000

Text for tendering purposes

TROX HESCO weather resistant louvres are installed in intake and outlet openings of buildings walls. Angular frame and blades of untreated aluminium with galvanized wire mesh, mesh width 12 mm.

