

Diffusion grilles

- Type DGVAR with STG3-VAR control device and touch display

Description of systems



TROX[®] TECHNIK



The art of handling air

TROX HESCO Schweiz AG
 Walderstrasse 125
 Postfach 455
 CH-8630 Rüti ZH

Tel. +41 55 250 71 11
 Fax +41 55 250 73 10
www.troxhesco.ch
trox-hesco@troxgroup.com

Contents · Safety instructions

1	DGVAR diffusion grille for temperature-dependent jet deflection3	
2	Touch display, control device and sensors	4
2.1	STG3-DIS touch display	4
2.2	STG3-VAR control device	4
2.3	KTF3-VAR duct air temperature sensor	5
2.4	RTF3-VAR room air temperature sensor	5
3	Functioning principle of the STG3-VAR control	6
4	Types of control for the STG3-VAR	7
4.1	Function diagram without measurement of the room air temperature	7
4.2	“Fixed points” without measurement of the room air temperature	7
4.3	“Regulated” without measurement of the room air temperature	7
4.4	Function diagram with measurement of the room air temperature	8
4.5	“Regulated” with measurement of the room air temperature	8
4.6	Fast heating via time switch	8
4.7	2-stage system with measurement of the room air temperature	8
4.8	“Manual” control	9
4.9	Additional function “adding / subtracting”	9
5	Connection diagram for the STG3-VAR control device with touch display	10
5.1	Standard layout	10
5.2	Layout with adder / subtractor	11
6	Settings on the touch display	12
6.1	Start window	12
6.2	Selection window	12
6.3	Setting the blade angle	12
6.4	Setting temperatures	12
6.5	Setting the temperature sensors	13
6.6	Setting the time switch times	13
6.7	Setting the language	13
7	Dimensions and installation of components	14
7.1	STG3-DIS touch display	14
7.2	STG3-VAR control device	15
8	SGA3-VAR control with setting control	16
9	Component electro-technical data	17
9.1	Actuator drive (TROX HESCO motor, type DGM06)	17
9.2	KTF3-VAR duct temperature sensor	18
9.3	RTF3-VAR room temperature sensor	18
9.4	Miscellaneous electro-technical notes	19
10	DGVAR grille: installation	20
11	DGVAR-STG3-VAR start-up	20
11.1	Blade positioning in relation to the STG3-VAR and SGA3-VAR control devices	20
11.2	Start-up	20

Safety instructions

WARNING!

Danger from incorrect use. Misuse of the product may lead to dangerous situations.

The product must not be used:

- in areas subject to explosion hazards;
- in the open air without sufficient protection against weather effects;
- in atmospheres that may have a damaging and/or corrosive effect on the product due to scheduled or unscheduled chemical reactions.

DANGER!

Electric shock when touching live parts. Electrical equipment is under dangerous electrical voltage. Non-compliance may lead to death, serious physical harm or material damage!

- Only electrical specialists may work on electrical components.
- Switch off the power supply voltage prior to electrical work.

WARNING!

Risk of injury due to insufficient qualifications!

Improper handling may lead to considerable personal harm or material damage.

- All activities may only be carried out by suitably qualified staff in building services.

1 DGVAR diffusion grille for temperature-dependent jet deflection

1 DGVAR diffusion grille for temperature-dependent jet deflection

(Details for the DGVAR grille, see brochure L-02-3-01e)

The DGVAR system is used for energy-saving supply air systems in large halls (e.g. trade fairs, manufacturing and storage halls, gyms, etc.), where efficient air distribution and the elimination of temperature layers is also important for comfort in the area for every operating point of the system.

The DGVAR diffusion grille is a supply air outlet, in which the horizontal air direction blades can be adjusted by motor dependent on the supply air temperature. If the supply air temperature is higher than the room air temperature (for heating), deflection will be directed downwards against the heating. For cooling, the jet is directed upwards.

With the DGVAR, the horizontal air directing blades can be turned until the opening cross section is closed on the grille. This option can be used for multiphase systems, in which a number of grilles identified in advance are closed for reduced amounts of supply air. The open grilles are therefore loaded more greatly, i.e. the blow out speeds produced will be almost the same as for full amounts of supply air.

During the heating up phase (period in which the room is not yet occupied by people), part of the grille will be closed for the full amount of supply air. Therefore, for grilles blowing out air (open grille), the blow-out speed, throw and induction will be significantly increased. The air jet will be directed downwards, as a result of which the heating up time is shortened and energy is saved, plus the temperature layers in the room are considerably reduced.

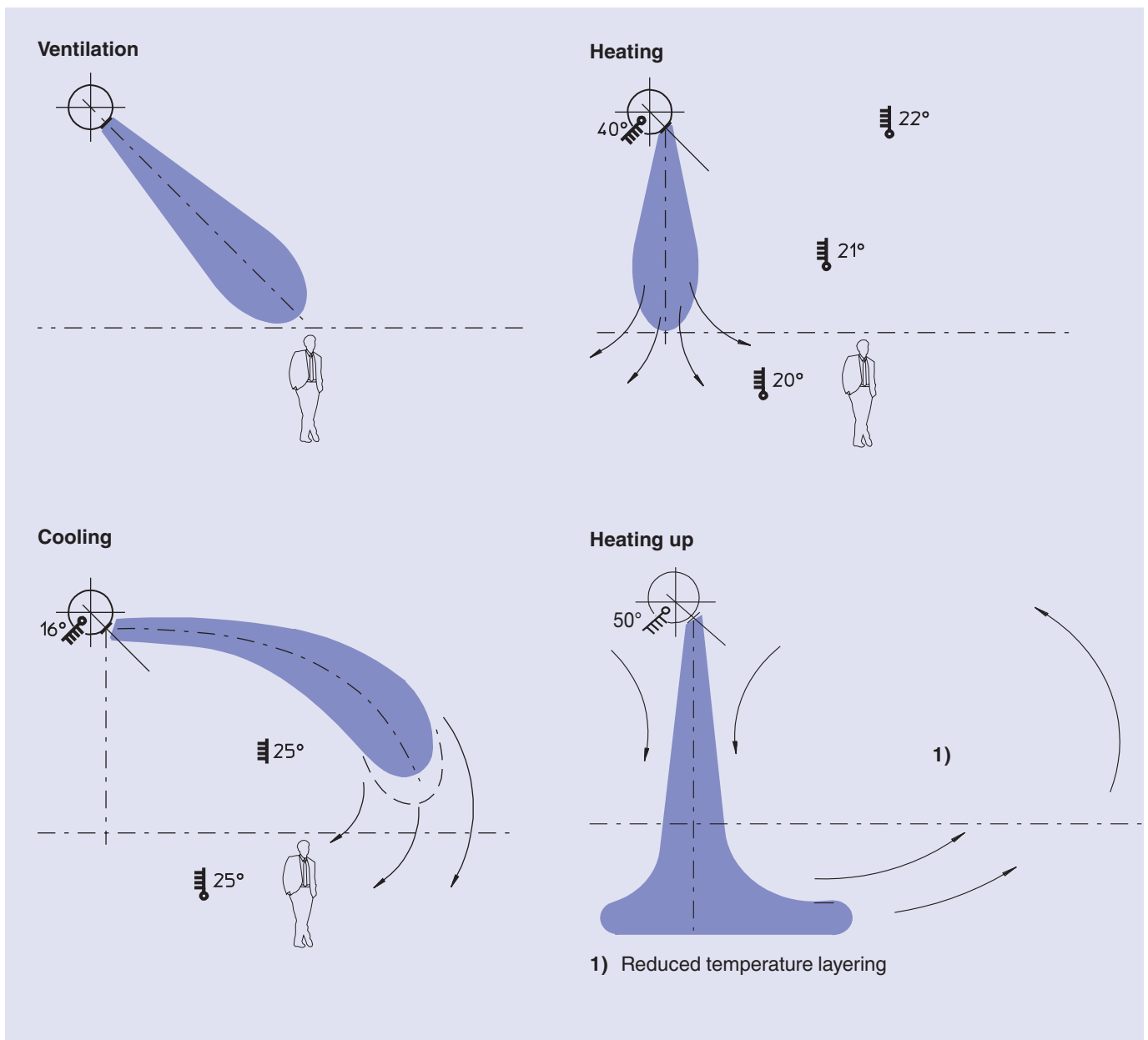

2 Touch display, control device and sensors

2 Touch display, control device and sensors

2.1 STG3-DIS touch display

The touch display is simple and convenient to use. An optional external 4.3" display enables simple setting and monitoring of all functions as well as the current temperature values and grille positions set. A digital real time clock is also built into the display, which can be used for switching times in the heating up phase.

A manual setting is also integrated for starting up the system. The touch display can be installed into a cupboard door or similar. Up to eight control devices can be connected to one touch display. A 24 VAC transformer fitted on-site provides power for the display.

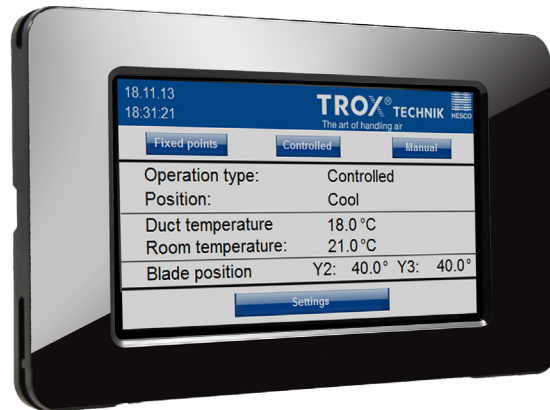

2.2 STG3-VAR control device

Control device with clamps for all outlets of the grille as well as the inlets for supply air and room air temperature. Up to 50 DGVAR grilles can be connected to a single control device. A 24 VAC transformer installed on-site enables the feed for the drives and the control device. Setting values can be pre-set on the display of the control device and the most diverse functions can be called up. In automatic mode, straight operation according to the supply air temperature as well as operation based on the temperature difference (supply air to room) can be selected. Manual adjustment is also built in for starting up the system. The control device can simply be snapped onto the control panel on a DIN rail.

Except for the switching times on the clock, all specifications can basically also be entered on this control device. However, it is simpler to enter parameters via the STG3-DIS touch display.

BUS communication

- MODBUS RTU built in as standard

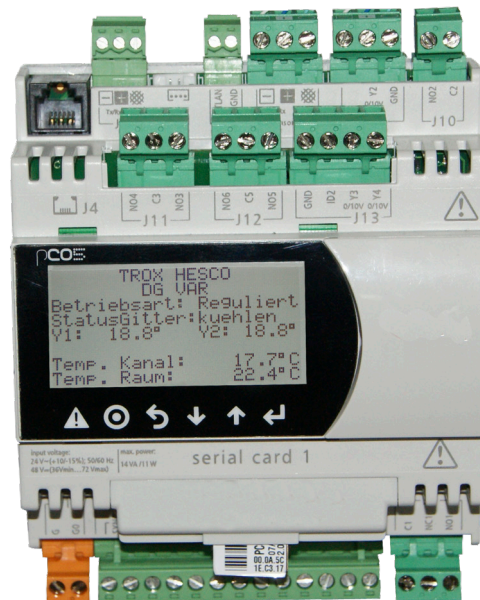

Note:

Up to 50 DGVAR diffusion grilles are connected on the STG3-VAR control device. A 24 VAC transformer fitted on-site provides power for the drives and the control device. The performance of the transformer is calculated based on the number of drives (see pos. 9.5).

2 Touch display, control device and sensors

2.3 KTF3-VAR duct air temperature sensor

Details, see pos. 9.3

To measure temperatures in air control ducts.

The following inputs are available:

- PT1000 (TROX HESCO design)
- 0...10 VDC



2.4 RTF3-VAR room air temperature sensor

Details, see pos. 9.4

Room temperature sensor for surface installation to measure temperature in rooms.

The following inputs are available:

- PT1000 (TROX HESCO design)
- 0...10 VDC



3 Functioning principle of the STG3-VAR control

3 Functioning principle of the STG3-VAR control

The positioning of the rear grille blades as a function of the supply air temperature in terms of the temperature difference is determined by the following parameters:

- Blade angle W1 at temperature T1 (input value)
- Blade angle W2 at temperature T2 = (T1 + T3) / 2 (automatically calculated value)
- Blade angle W3 at temperature T3 (input value)
- Question mark [?] = help information

According to these inputs, the control curve for the grille angle is defined.

Application example:

Set blade angle			
Angle W1 (cool):	(7.0...8.5 V)	8.0	40.0°
Angle W2 (ventilate):	(5.0...7.0 V)	6.0	0.0°
Angle W3 (heat):	(4.0...5.0 V)	4.0	-40.0°
Angle W4 (heat up):	(3.0...4.0 V)	3.5	-50.0°

Temperature setting	
Temperature T1 (min):	18.0 °C
Temperature T2 (mid):	21.0 °C = Average
Temperature T3 (max):	24.0 °C

Without room air temperature measurement

Blade angle = 0° (blowing out straight)

Example plotted with T2 = 21°C

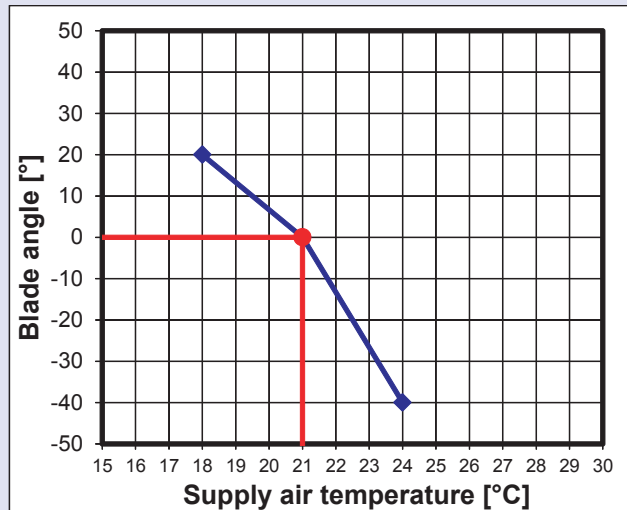

with room air temperature measurement

- Left curve: Blade angle = -40° ($\Delta t = +3$ K)
- Middle curve: Blade angle = 0° (blowing out straight)
- Right curve: Blade angle = +20° ($\Delta t = -3$ K)

Example plotted with T2 = 21°C

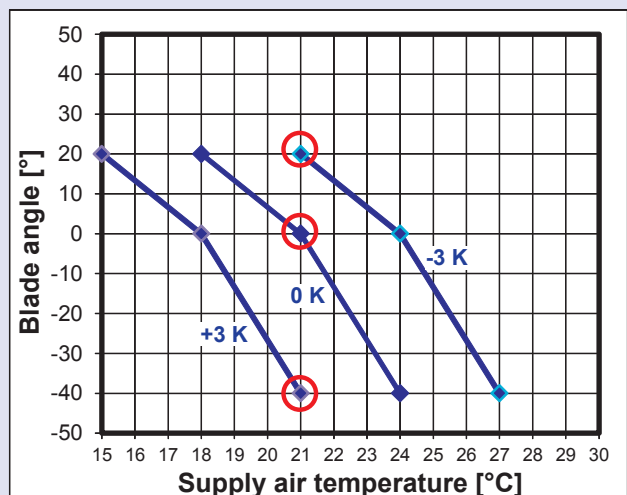

$$\Delta t = (t_{zul} - t_R) = \text{supply air temp} - \text{room air temp}$$

4 Types of control for the STG3-VAR

4 Types of control for the STG3-VAR

4.1 Function diagram without measurement of the room air temperature

1. DGVAR grille
2. STG3-VAR control device
3. STG3-DIS touch display with built-in timer switch
4. 230 VAC/24 VAC transformer
5. 230 VAC/24 VDC transformer
6. Input cable Td 3 x1,5 mm² (Td 5 x1,5 mm²)
7. Ribbon cable (5-wire recommended)
8. KFT3-VAR duct air temperature sensor
9. Optional time switch for quick heating up
10. Air control

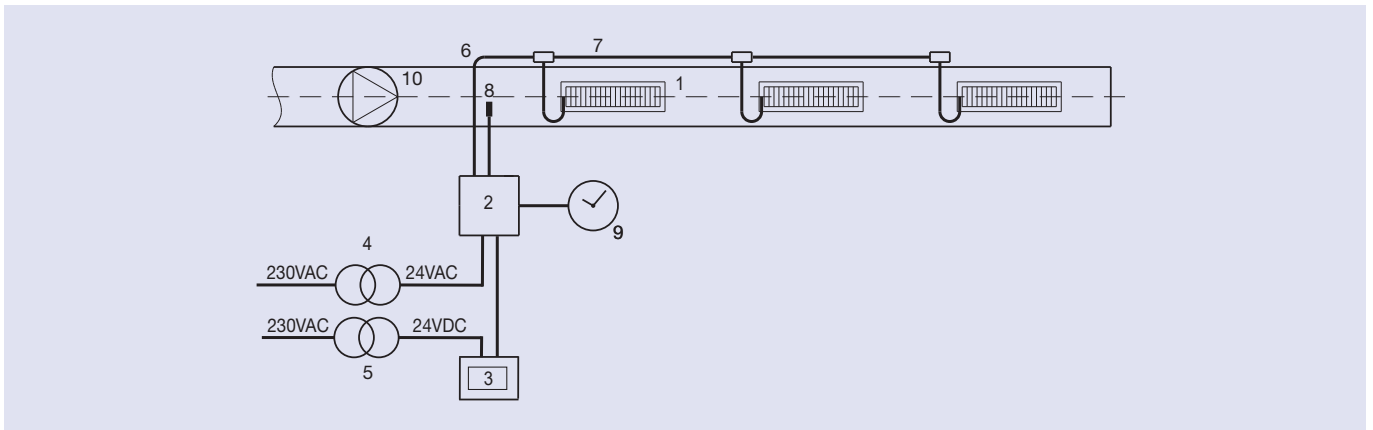

4.2 “Fixed points” without measurement of the room air temperature

This type of control corresponds to the version with the earlier STG2VAR control device.

If the air temperature in the duct is lower than the set temperature value T1, the blades of the DGVAR grille are set fixed at position W1. This is usually set so that the air jet is raised (cooling).

If the air temperature is between target values T1 and T3, then the blades of the DGVAR grille are set fixed at position W2. This is usually set so the air blows out straight (isothermic air supply).

If the air temperature is set above the target value T3, the blades of the DGVAR grille are set fixed at position W3. This is usually set so that the air blows out downwards (heating).

4.3 “Regulated” without measurement of the room air temperature

If the air temperature in the duct is lower than the set temperature value T1, the blades of the DGVAR grille are set fixed at position W1. This is usually set so that the air jet is raised (cooling).

If the air temperature in the duct is between the temperature values T1 and T2, the blades of the DGVAR grille are set correspondingly between the values W1 and W2.

If the air temperature in the duct is between the temperature values T2 and T3, the blades of the DGVAR grille are set correspondingly between the values W2 and W3.

If the air temperature in the duct is higher than the set temperature value T3, the blades of the DGVAR grille are set fixed at position W3. This is usually set so that the air jet is directed downwards (heating).

4 Types of control for the STG3-VAR

4.4 Function diagram with measurement of the room air temperature

1. DGVAR grille
2. STG3-VAR control device
3. STG3-DIS touch display with built-in timer switch
4. 230 VAC/24 VAC transformer
5. 230 VAC/24 VDC transformer
6. Input cable Td 3 x1,5 mm² (Td 5 x1,5 mm²)
7. Ribbon cable (5-wire recommended)
8. KTF3-VAR duct air temperature sensor
9. Optional timer switch for quick heating up
10. Ventilator
11. RTF3-VAR room air temperature sensor

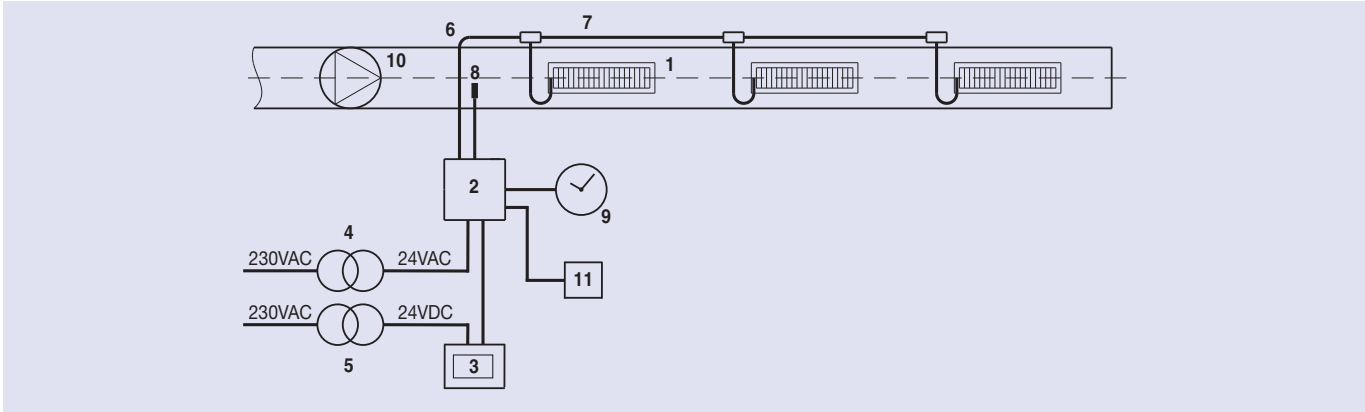

4.5 “Regulated” with measurement of the room air temperature

In this type of control the DGVAR grille is set according to the temperature difference between the supply air and room air temperature.

Essentially, the same blade setting procedure applies as for pos. 4.3, without measurement of the room air temperature. However, the positions of the base curves vary depending on the temperature difference (see chapter 3).

4.7 2-stage system with measurement of the room air temperature

1. DGVAR grille
2. STG3-VAR control device
3. STG3-DIS touch display with built-in timer switch
4. 230 VAC/24 VAC transformer
5. 230 VAC/24 VDC transformer
6. Input Td 3 x1,5 mm² (Td 5 x1,5 mm²)
7. Ribbon cable (5-wire recommended)
8. KTF3-VAR duct air temperature sensor
9. Optional timer switch for quick heating up
10. Ventilator
11. Room air temperature sensor, RTF3-VAR
12. Protection auxiliary contacts for 2-stage operation

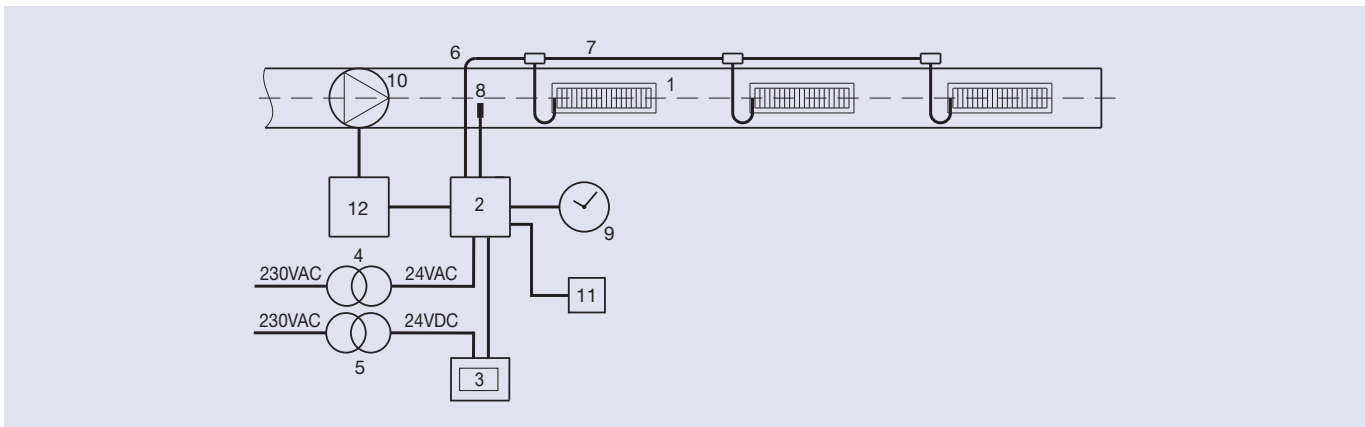

With a 2-stage system, for example, half the number of DGVARs can be closed on the lower level (reduced volume flow) via a protection auxiliary contact. The remaining half continues to regulate flow according to temperature, as described before.

If a system is combined with a multispeed ventilator as well as the quick heating up function, the same DGVARs close with reduced blow in as for quick heating up.

4 Types of control for the STG3-VAR

4.8 “Manual” control

The blow out position required in the “manual” type of control is set via the W5 position control. On the display, the “manual” type of control is shown. The manual control is primarily used for initial installation and start-up.

4.9 “Adder-subtractor” additional function

The PAS3VAR “adder-subtractor” is an additional function to supplement all types of control described before. It is used if the supply air jet is to blow out from one or more DGVAR diffusion grilles at a different angle compared to the other DGVAR diffusion grilles.

TROX [®] TECHNIK HESCO			
The art of handling air			
02.09.16 10:03 #1			
Set blade angle			
Angle W1 (cool):	(7.0...8.5 V)	8.0	40.0°
Angle W2 (ventilate):	(5.0...7.0 V)	6.0	0.0°
Angle W3 (heat):	(4.0...5.0 V)	4.0	-40.0°
Angle W4 (heat up):	(3.0...4.0 V)	3.5	-50.0°
Angle W5 (manual):	(3.5...8.5 V)	5.5	-10.0°
Offset Add.-Subtr.:	(-2.0...2.0 V)	1.0	

1. DGVAR grille
2. STG3-VAR control device
3. STG3-DIS touch display with built-in timer switch
4. 230 VAC/24 VAC transformer
5. 230 VAC/24 VDC transformer
6. Input cable Td 3 x1,5 mm² (Td 5 x1,5 mm²)
7. Ribbon cable (5-wire recommended)
8. KTF3-VAR duct air temperature sensor
9. Optional timer switch for quick heating up
10. Ventilator
11. RTF3-VAR room air temperature sensor
12. Protection auxiliary contacts for 2-stage operation

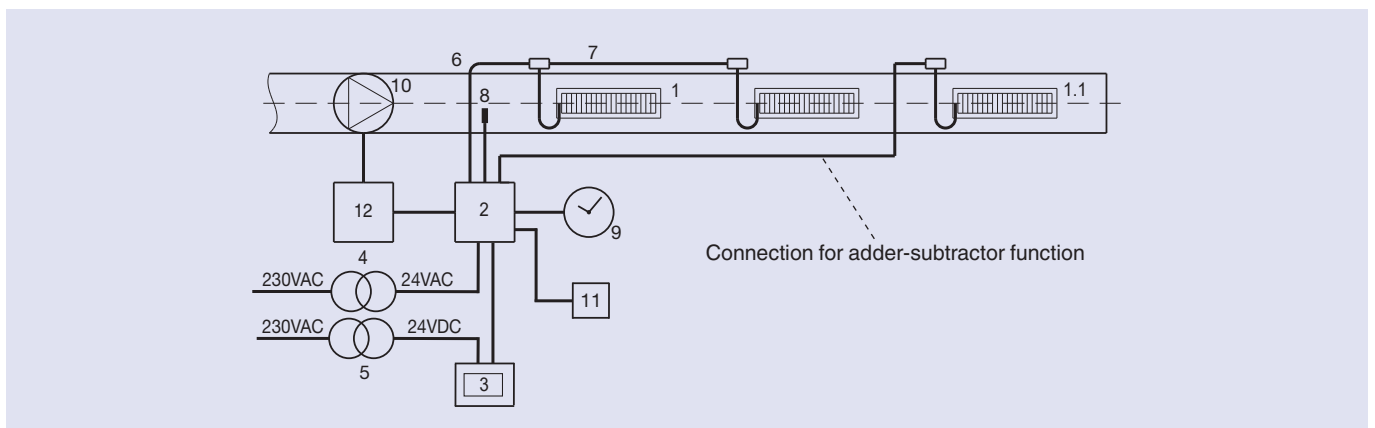

For this function (additional function) to be carried out, it is vital that a 5-wire connection cable is in place from the control device (pin Y4, clamp J13) to the sockets of the DGVAR air outlets. The feed for the STG3-VAR and the DGVAR is carried out via a 24V transformer (24 VAC). For the STG3-DIS a 24V transformer (24 VDC) is needed.

The air jet can blow out at a maximum offset angle of approximately 30° (in the software, this corresponds to ±2VDC).

The practical benefits are numerous: e.g. for subsequent building alterations, such as the installation of galleries, crane rails, traverses, beams, etc., blowing can take place “around” these obstructions. This prevents draughts from occurring and increases the effectiveness of the control. Comfort can therefore be increased considerably in the places compromised within the occupied space.

5 Connection diagram for the STG3-VAR control device with touch display

5 Connection diagram for the STG3-VAR control device with touch display

5.1 Standard design

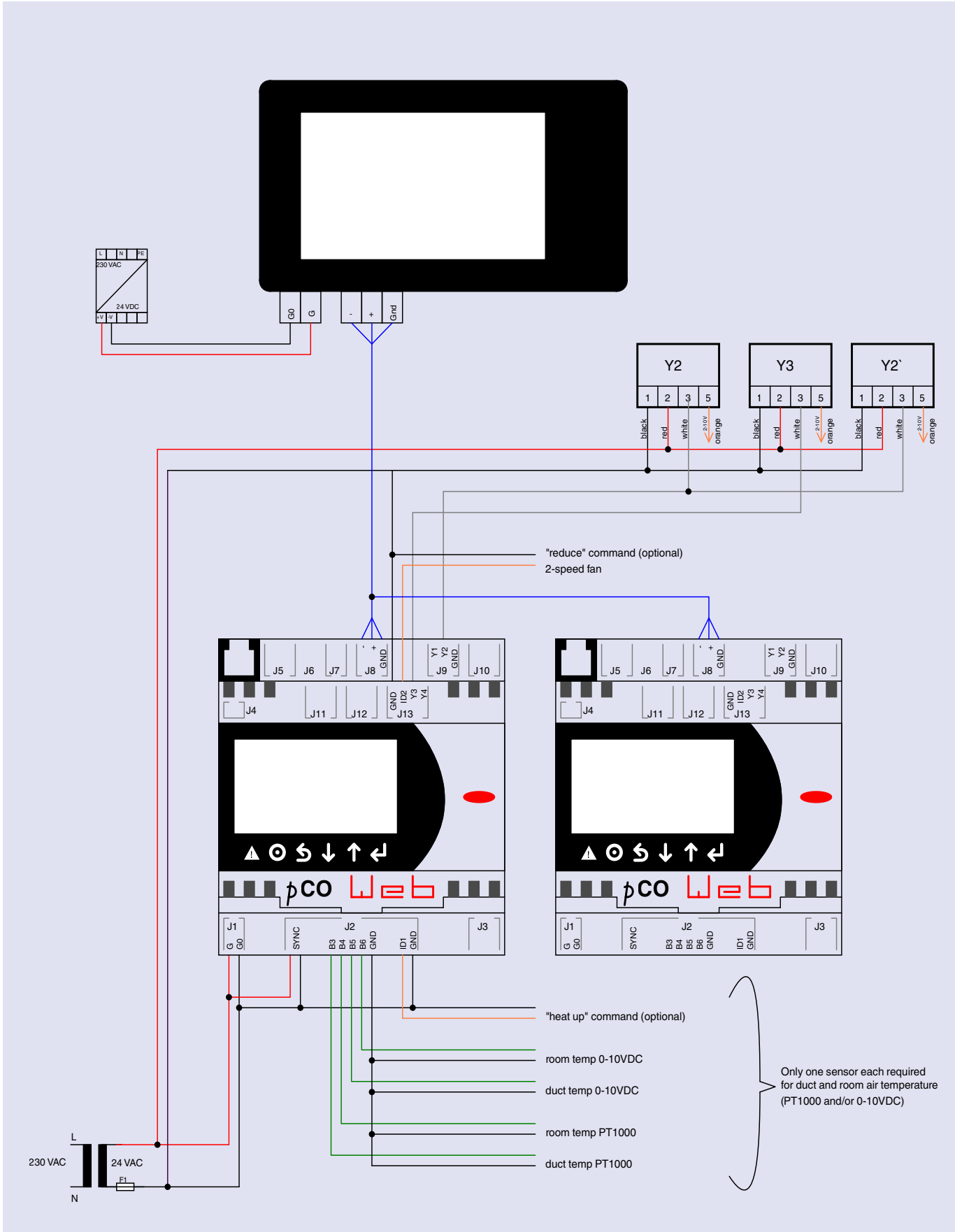

5 Connection diagram for the STG3-VAR control device with touch display

5.2 Design with adder-subtractor

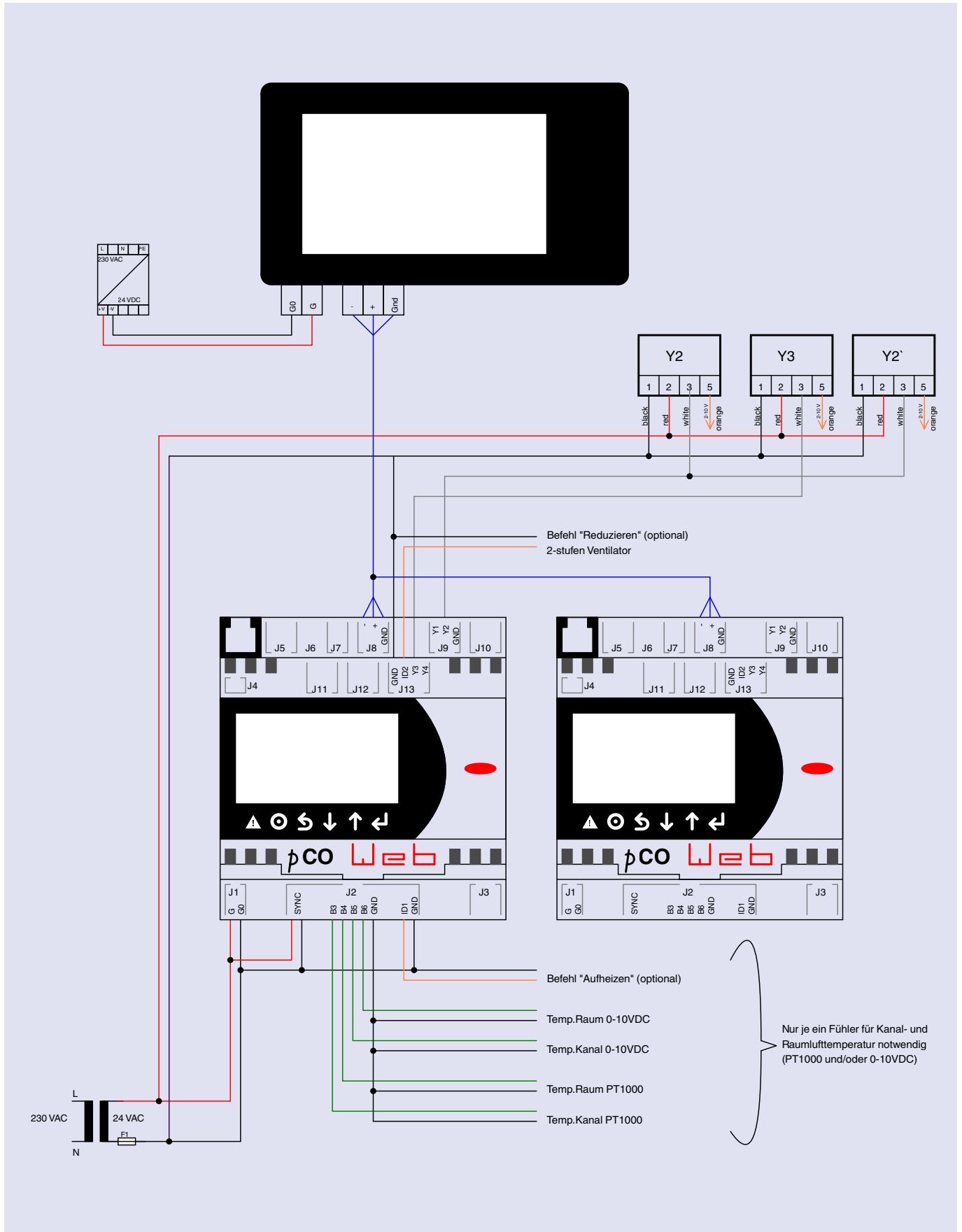

6 Settings on the touch display

6 Settings on the touch display

6.1 Start window

- Choice of function type [fixed points], [controlled] or [manual] as well as [settings]
- Function type set
- Current function, “cool”, “ventilate” or “heat”
- Value of the duct temperature
- Value of the room temperature
- Current blade setting, Y2 and Y3
- Selection of the device address (1...8)

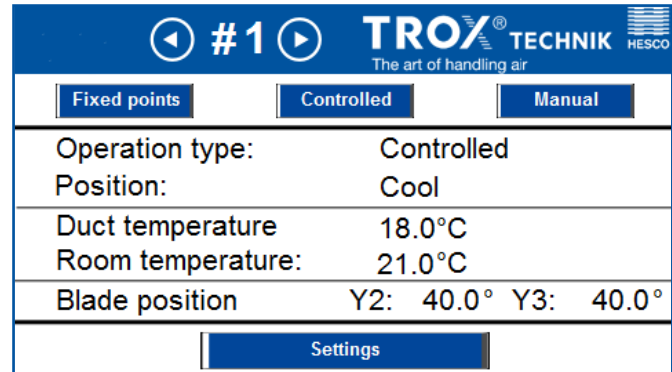

6.2 Selection window

- Selection menu for [temperatures], [temperature sensors], [blade angle], [language], [timer switch] [date and time] [number of STG3-VAR control units]

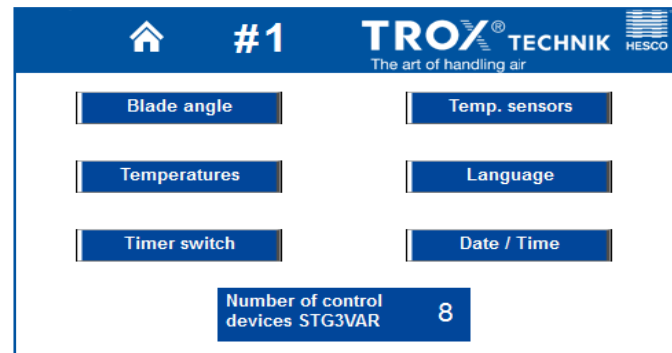

6.3 Setting the blade angle

- Angle specification W1 for the cooling operation (~7.0-8.5 V)
- Angle specification W2 for the ventilate operation (~5.0-7.0 V)
- Angle specification W3 for the heating operation (~4.0-5.0 V)
- Angle specification W3 for the heating up operation (~3.0-4.0 V)
- Angle specification W3 for manual operation
- Offset Adder-Subtractor (-2.0...2.0 V)
- Question mark [?] = help information

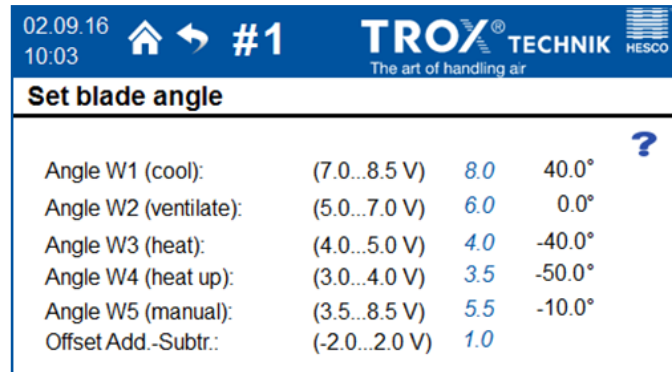

6.4 Setting temperatures

- Lower limit temperature T1 (~16...22°C)
- Middle temperature T2 = (T1 + T3) / 2
- Upper limit temperature T3 (~22...30°C)
- Question mark [?] = help information

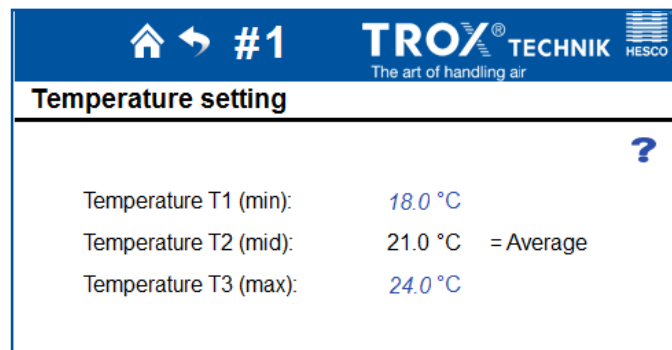

6 Settings on the touch display

6.5 Setting the temperature sensors

- Choose temperature sensor in the supply air duct (0-10 VDC) or (Pt1000)
- Choose temperature sensor in the room (0-10 VDC) or (Pt1000)
- Correction offset of the measured values for true temperature
- Setting ramp for type 0-10 VDC
- Question mark [?] = help information

Set temperature sensors

Duct temperature sensor: PT1000 **change** ?
 offset: 0.0°C

Room temp. sensor: 0-10 V **change**
 Offset: 0.0°C
 Area: 0 V = 0.0°C 10 V = 50.0°C

6.6 Setting the timer switch times

Specification of the on and off switching times for the fast heat, which may be set differently for Monday to Sunday.

Heat up timer switch, Monday

Switch on: 05 : 00
 Switch off 07 : 00

Heat up timer switch

	Active	On	Off
Monday		00 : 00	00 : 00
Tuesday		00 : 00	00 : 00
Wednesday		00 : 00	00 : 00
Thursday		00 : 00	00 : 00
Friday		00 : 00	00 : 00
Saturday		00 : 00	00 : 00
Sunday		00 : 00	00 : 00

6.7 Setting the language

- Choice of language from:
 German,
 French,
 English,
 Italian

Deutsch Français
 English Italiano

6.8 Setting the date and time

- Synchronisation automatically every 24 hours
- Synchronisation manually hold button for 5 seconds

Date and time adjustment

Date: 01.04.2014
 Time: 11:48

synchronize manually

7 Dimensions and installation of components

7 Dimensions and installation of components

7.1 STG3-DIS touch display

The touch display can be mounted on panels of 6 mm thickness maximum.

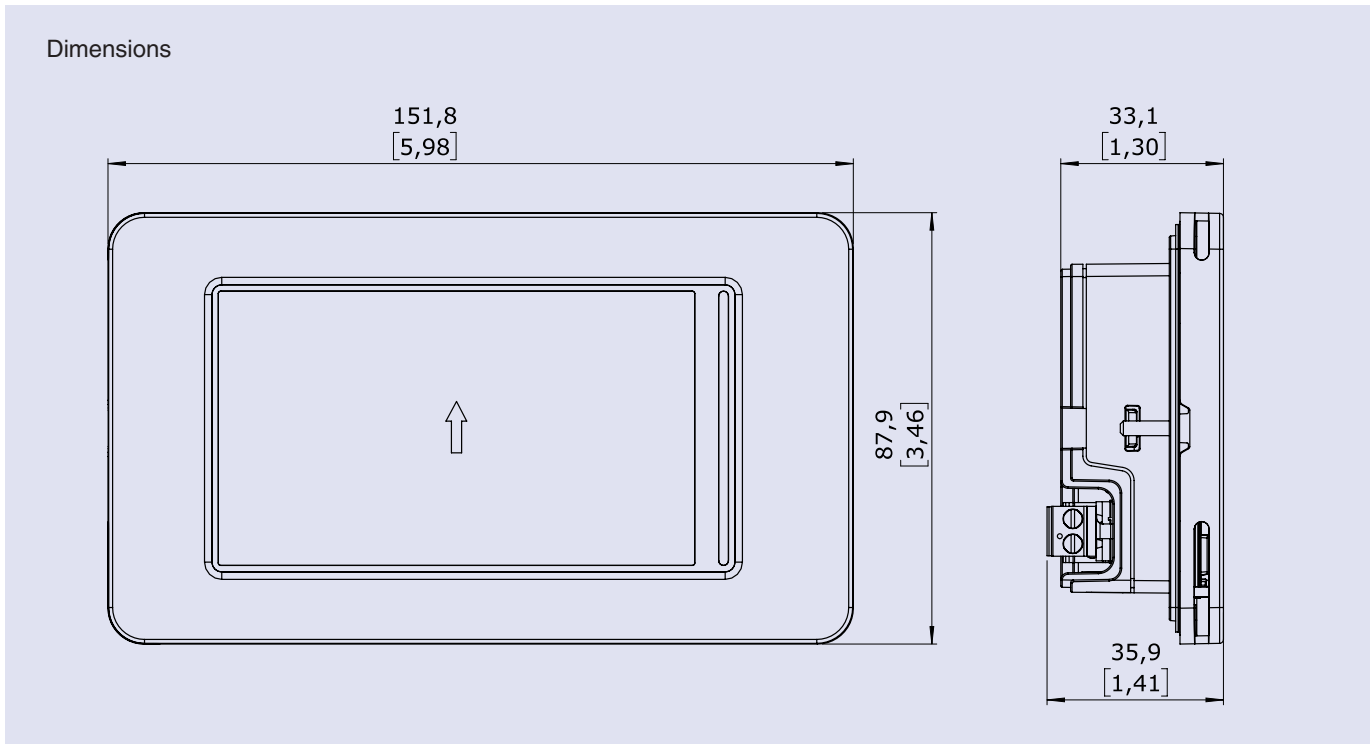

Installation

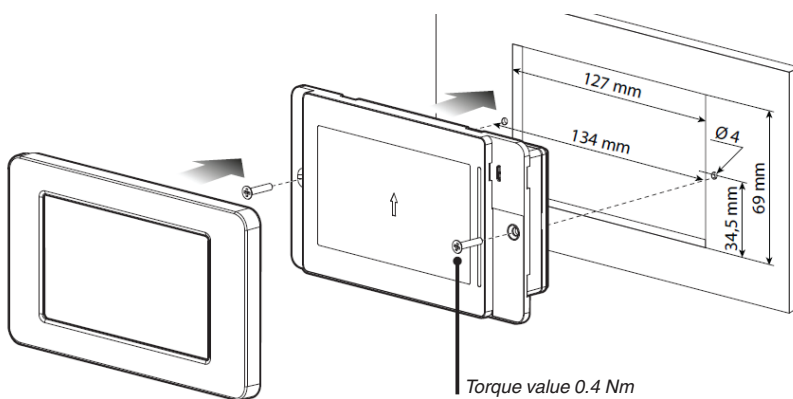

Power supply
24Vdc -10% + 10%
7 W = 24 Vdc * 0.29 A

7 Dimensions and installation of components

7.2 STG3-VAR control device

Installation

The STG3-VAR control device is installed on a control panel on a top-hat rail. When the rear springs are snapped on, the control is clamped onto the rails. It can also be extended easily in the same way; place a screwdriver on the notched opening of the springs to lift it. The springs are held in the locked position by return springs.

Power supply

The control must always be fitted with an earthed clamp between G and G0. The power supply is connected between G and G0.

A control box requires a 14 VA safety transformer of class II with a 24 VAC outlet voltage as a power supply. Should several controls be supplied by the same transformer, the nominal voltage must be $n \times 14$ VA, where n is the number of controls to be supplied by the transformer. To connect the power supply to clamp J1, a cable with 1mm^2 minimum profile must be used.

Dimensions

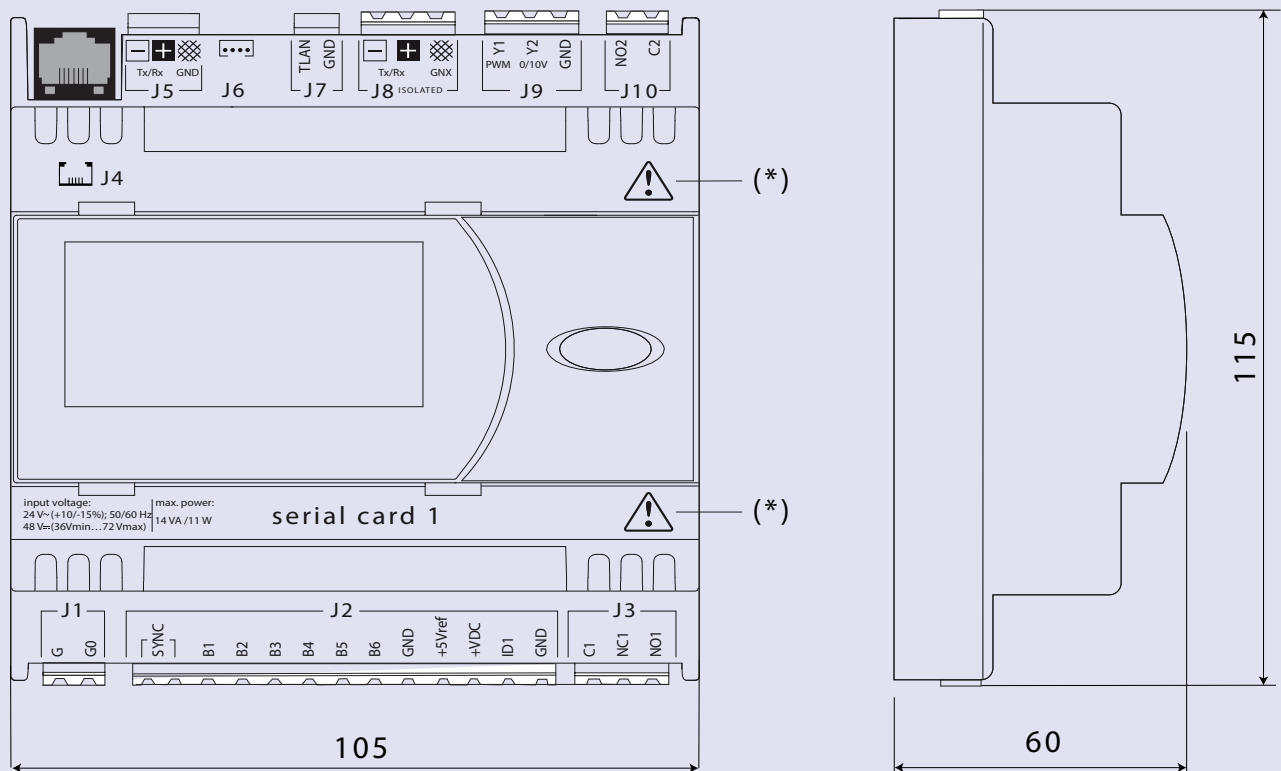

* Safety notes

Install a separator according to the regulations.

A mains voltage that does not comply with the regulations may seriously damage the system.

Use suitable cable shoes for the clamps. Loosen each screw, insert the cable shoes and then tighten the screws. Finally gently tighten the cables and check they are sitting securely.

Separate the cables of the sensor signals and the digital inputs from the inductive loads cables and from the power cables, as far as possible, to avoid electromagnetic interference. Never put power and sensor cables in the same cable ducts (including power cable ducts). Never install the sensor cable close to the power protection (protection switch, thermo-switch, etc.).

8 Control with SGA3-VAR position control

8 SGA3-VAR control with position control

Note:

This type of control is not a true DGVAR system (without control device, without touch display, without timer switch and without quick heating up).

1. DGVAR grille
2. STG3-VAR control device
3. 230 VAC/24 VAC transformer
4. Input cable Td 3 x1,5 mm² (Td 5 x1,5 mm²)
5. Ribbon cable (5-wire recommended)
6. Ventilator

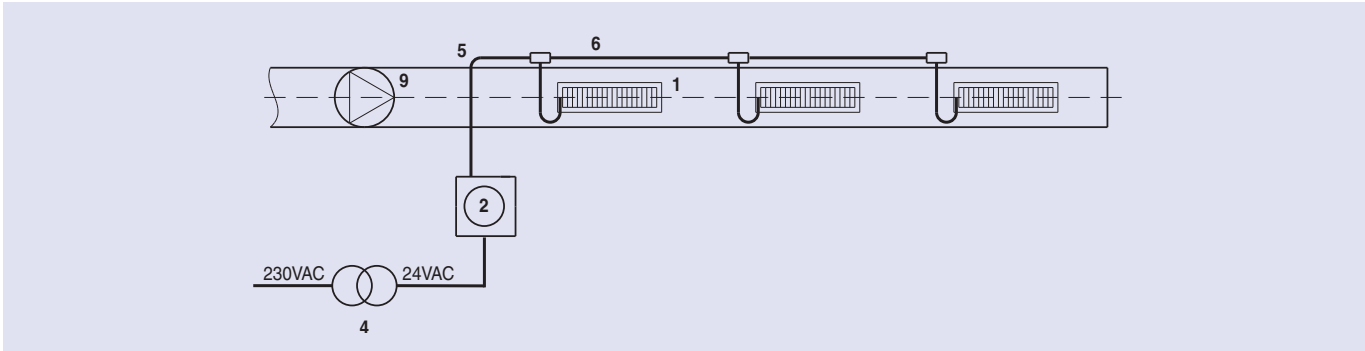

The blades of the DGVAR are set manually on the setting control at the blow out angle required. At position 0 the grilles are closed. Up to 50 DGVAR grilles can be controlled using the position control. The static pressure in the duct is to be checked using a pressure transducer and the fan power reduced. We will not assume costs for damage arising from disregard of the above explanations (e.g. duct blowouts).

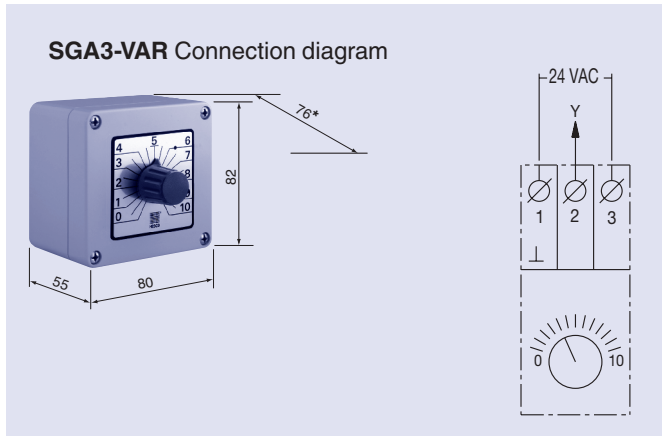
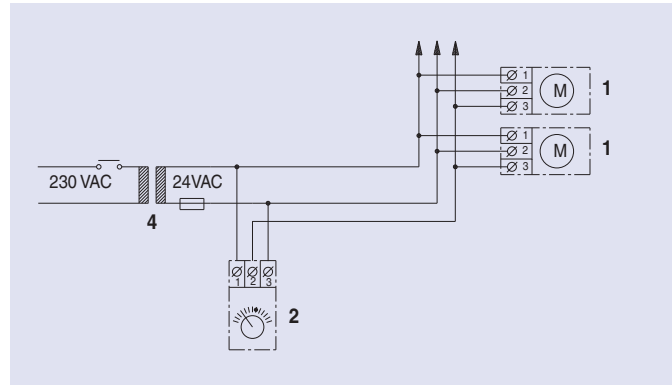

An on-site 24 VAC transformer ensures supply to the drives. The capacity of the transformer (4) is to be calculated based on the number of drives (calculation details for transformers, see pos. 9.5). Protection must be designed according to the details of the transformer manufacturer.

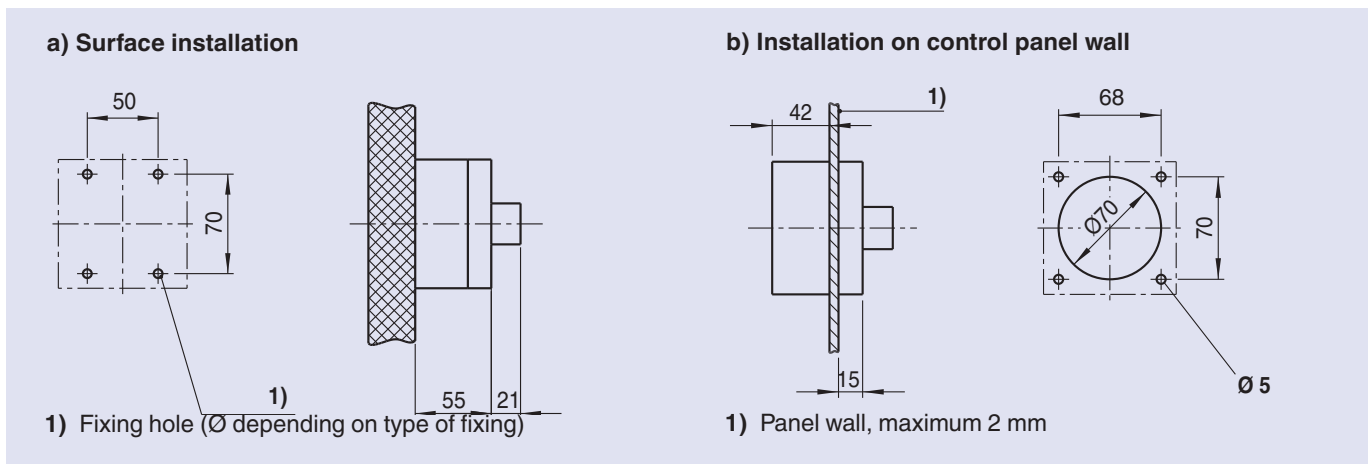

9 Component electro-technical data

9 Component electro-technical data

9.1 Actuator driver (TROX HESCO motor type DGM06)

Technical data

- Nominal voltage 24 VAC, 50/60 Hz
- Control voltage DC 2...10 VDC (control signal Y)
- Rating 4 VA
- Power consumption 1 W at nominal torque (for transformer calculation see details under "Output", page 19)
- Running time 90 seconds
- Ambient temperature -30 to +50°C
- Protection type IP54

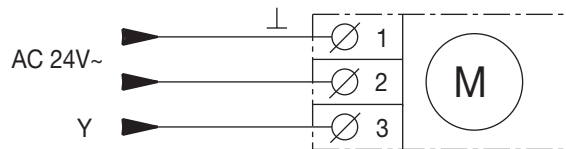

Note

The DGVAR actuator driver, type DGM06 is a built-in part of the DGVAR air outlet. The DGVAR diffusion grille and actuator driver are always delivered assembled (factory checked). Actuator drivers without a DGVAR diffusion grille are not supplied.

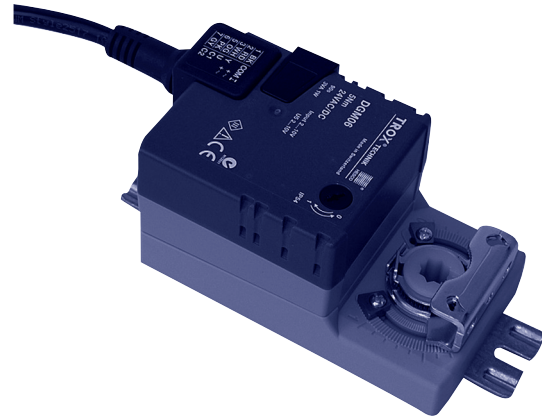

9 Component electro-technical data

9.2 KTF3-VAR duct temperature sensor

For measurement of supply air temperature with passive sensor type PT1000, including installation flange.

Connection: 2-lead, A-B clamps

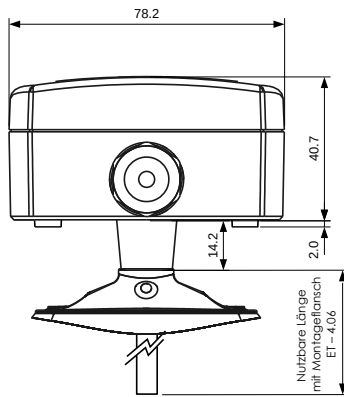
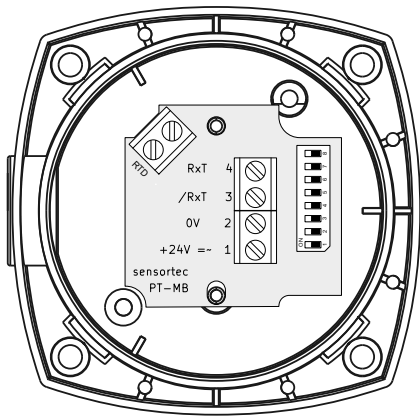

Clamp	Connection
1	Powersupply 24 VAC/DC
2	GND
3	/RxTx (RS-485 +)
4	RxTx (RS-485 -)
RTD	Connexion PT 1000 pour 2 clamps

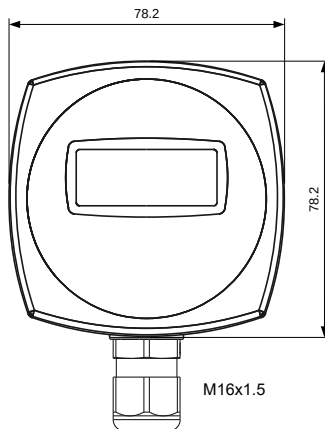

9.3 RTF3-VAR room temperature sensor

Room temperature sensor for wall installation to measure temperature in rooms. The temperature sensor is fitted with a passive measuring element, type PT1000.

Connection: 2-lead, A-B clamps

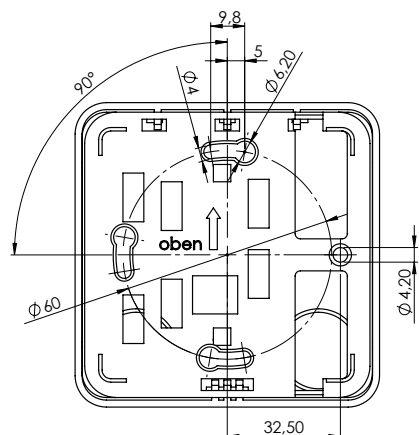
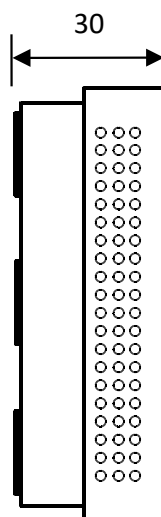
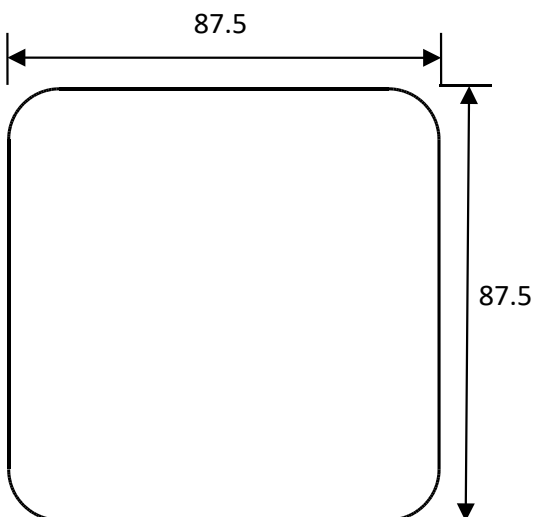

9 Component electro-technical data

9.4 Miscellaneous electro-technical notes

Installations

It is easiest to carry out the installation right on the duct with a 5-wire ribbon cable (e.g. made by Woertz, Basel). This system includes a 5-wire cable, distribution boxes for connecting the DGVAR motors plus buckles, junction boxes and end pieces.

- 1) 5-wire ribbon cable and distribution box
(e.g. made by Woertz, Basel)
- 2) Motor cable (3-wire)

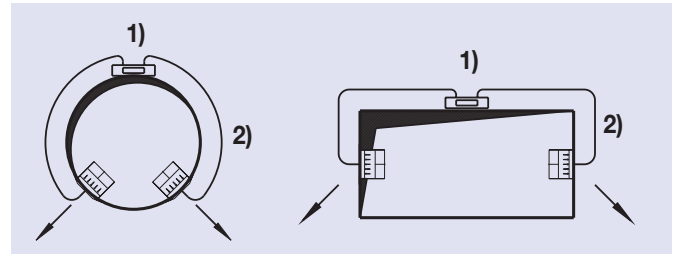

Output

To calculate the transformer output the number of DGVAR drives is multiplied by 4 VA.

Added to this is the power requirement for the touch display and the control device.

Beispiel STG3-DIS:

1 STG3-DIS	7 W
Transformer (on site)	24 VDC, 7 W

Example DGVAR and STG3-VAR:

2 STG3-VAR 2 x 14 VA	28 VA
30 DGVAR grille 30 x 4 VA	120 VA
Total	148 VA
Transformer (on site):	24 VAC, 148 VA

The value obtained is usually rounded up to the next-highest off-the-shelf value.

Input

For the input (from the control device to the ribbon cable) a minimum of 1.5 mm² wire should be used. For long inlets as well as for a large number of motors at the same cable, the voltage drop here should be taken into account. Care should be taken here that each motor receives a voltage of 24 VAC \pm 20% between clamps 1 and 2.

For calculating the voltage drop in the cable, a load capacity of 2 VA per DGVAR should be used. At the control device, STG3-VAR, a maximum of 2 wires may be connected per clamp. For several power cables a distribution box should be installed in front of the STG3-VAR control device.

Important note

If the system is switched on and off on the secondary side (24 VAC~, 50 Hz), then the input is to be switched to 2-way.

10 DGVAR grille: installation

11 DGVAR-STG3-VAR start-up

10 DGVAR grille: installation

Detailed information about variants of the DGVAR grille, dimensions, installation, tender texts and order codes are described in the “diffusion grille” (L-02-3-01e) documentation.



11 DGVAR-STG3-VAR initial installation and start-up

11.1 Blade positioning in relation to the STG3-VAR and SGA3-VAR control devices

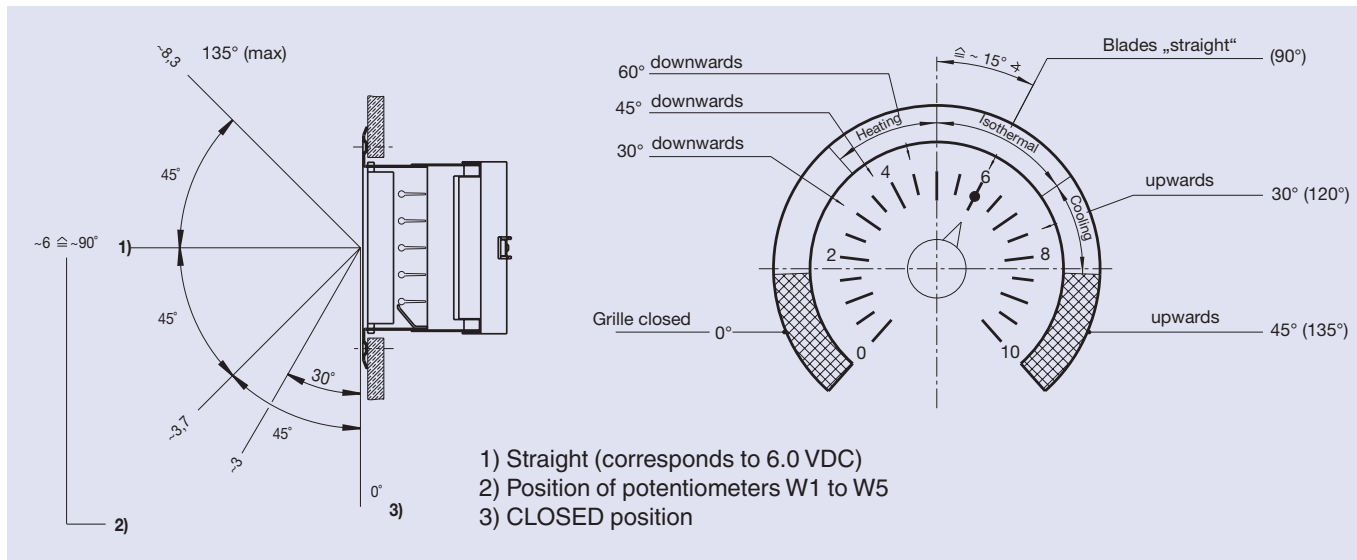

11.2 Start-up

- Check installations and wiring.
- Switch on mains and check whether 24 VAC for STG3-VAR and DGVAR as well as 24 VDC for STG3-DIS is available (fan OFF).
- Set “manual” on the touch display.
- With digital entry of the voltage values at the angle specification W5, it should be checked whether all outlets are working and whether all are running in parallel to one another in both directions. The blow-out direction of the rear grille blades should follow the instructions according to pos. 11.1.
- If the grille positions are correct, the angle specifications, W1, W2, W3 and W4 can be entered, along with temperature limits T1 and T3. If nothing is specified to the contrary, the standard values according to pos. 6.2 and 6.3 (display details) can be selected.
- Switch on the fan: the system should now be functioning correctly

The precise setting of W1, W2, W3 and W4 must now be carried out based on the supply air temperature, installation situation of the DGVAR and the on-site features and can only be finally regulated after a certain operating period (smoke tests).

Note:

Depending on the type of application, the static pressure in the duct must be checked using a pressure transmitter and the fan capacity reduced. We cannot assume any costs for damage (e.g. duct blowouts) resulting from disregard of the explanations.